

Montageanvisning Tall Infästning Ø108 fundament

Assembly instruction Tall Attachment Ø108 base

S. Det är lämpligt att denna information överlämnas till användaren av anläggningen.

GB. It is appropriate that this information is passed on to the user of the installation.

D. Diese Informationen sind für den Benutzer der Anlage vorgesehen.

SF. Tämä ohje on suositeltava luovuttaa.

FÖRSKRUVNING 2ST KABEL Ø 5-13
CABLE GLAND 2 PCS CABLE Ø 5-13

TA BORT TOPP 4ST SKUVAR
REMOVE TOP 4 PCS. SCREW
ÅTDRAGNINGSMOMENT 4Nm
TIGHTEN TORQUE 4Nm

KOPPLINGSPLINT 5x2,5mm²
TERMINAL BLOCK 5x2,5mm²

SKRUVBRICKA M12 RF
SCREW/WASHER M12 STAINLESS
ÅTDRAGNINGSMOMENT 50Nm
TIGHTEN TORQUE 50Nm

PACKNING
GASKET

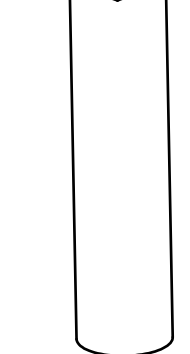
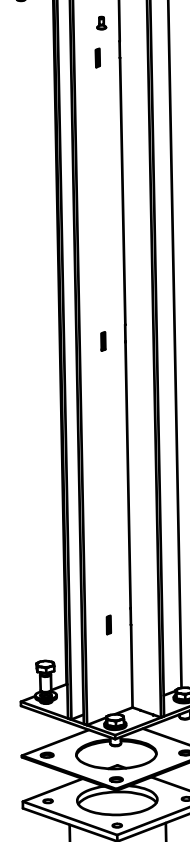
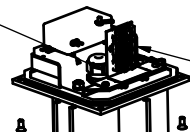
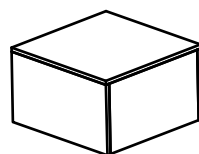
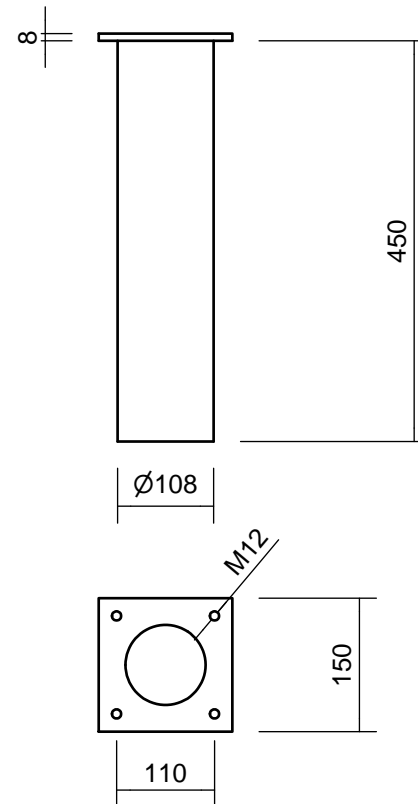

S. Om armaturens kabel skulle skadas eller om armaturen inte fungerar som den ska, skall dessa komponenter kontrolleras/bytas av tillverkaren eller av tillverkaren utsedd person.

GB. If the luminaire cable is damaged or if the luminaire is not working properly, it shall exclusively be checked/replaced by the manufacturer or by the manufacturer designated person.



ateljé Lyktan

SE-296 81 Åhus, Sweden

Tel: +46 44 28 98 00

Fax: +46 28 98 38

info@ateljje-lyktan.se

www.ateljje-lyktan.se

MA205381

2012-08-27

SCN

S. Det är lämpligt att denna information överlämnas till användaren av anläggningen.

GB. It is appropriate that this information is passed on to the user of the installation.

D. Diese Informationen sind für den Benutzer der Anlage vorgesehen.

SF. Tämä ohje on suositeltava luovuttaa.

Montageanvisning Tall Infästning platsgjutning 205382

Assembly instruction Tall Anchorage unit 205382

S. Om armaturens kabel skulle skadas eller om armaturen inte fungerar som den ska, skall dessa komponenter kontrolleras/bytas av tillverkaren eller av tillverkarens utsedd person.

GB. If the luminaire cable is damaged or if the luminaire is not working properly, it shall exclusively be checked/replaced by the manufacturer or by the manufacturer designated person.



atelje Lyktan

SE-296 81 Åhus, Sweden

Tel: +46 44 28 98 00

Fax: +46 28 98 38

info@atelje-lyktan.se

www.atelje-lyktan.se

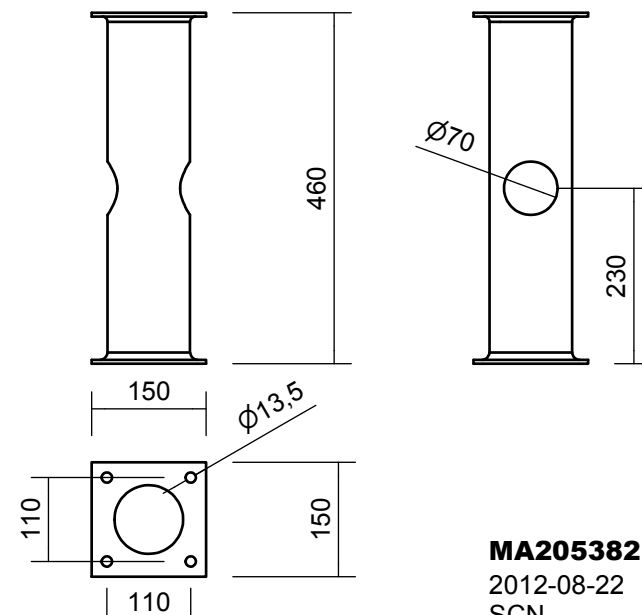
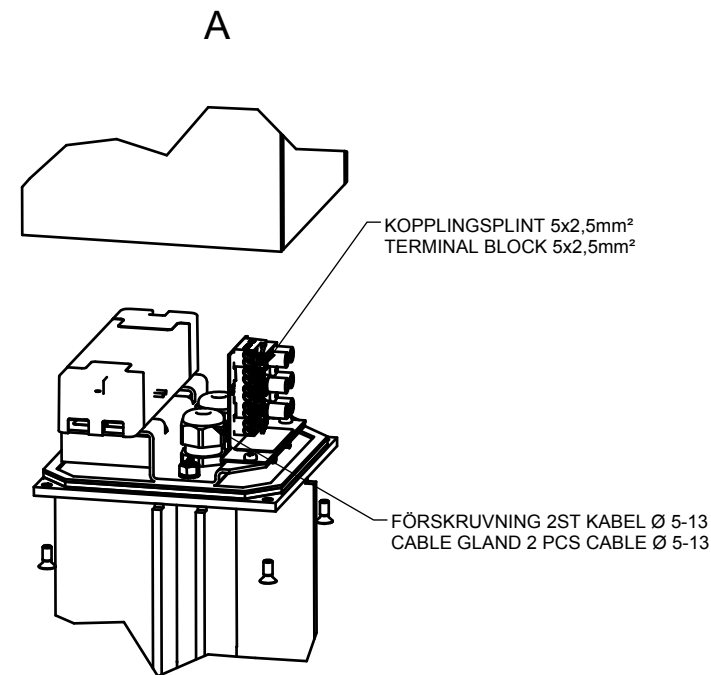
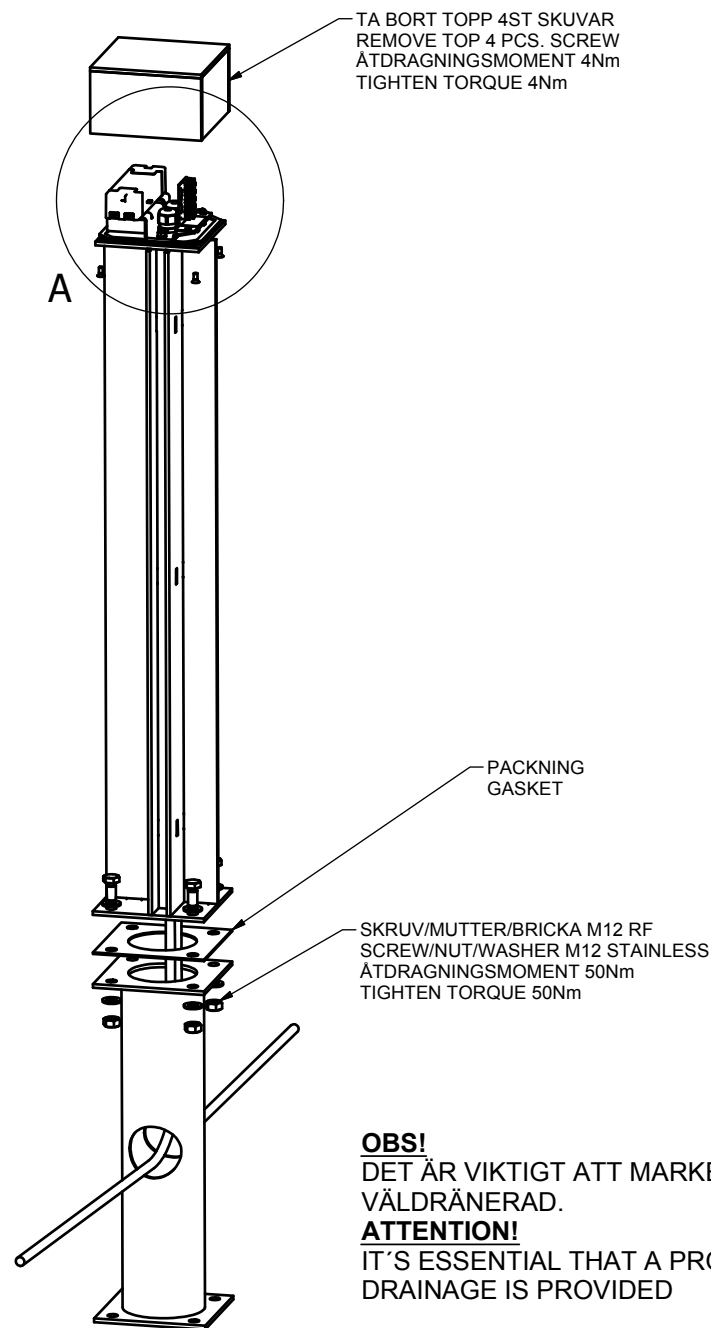

MA205382

2012-08-22

SCN